



**INSPECTION, MAINTENANCE AND
RECHARGE SERVICE MANUAL
P/N 05603**

All fire extinguishers should be installed, inspected and maintained in accordance with the National Fire Protection Association standard titled "Portable Fire Extinguishers", NFPA-10 and the requirements of local authorities having jurisdiction.

When maintenance is indicated, it should be performed by trained persons having proper equipment. Fire extinguishers are pressure vessels and must be treated with respect and handled with care. They are mechanical devices and require periodic maintenance to be sure that they are ready to operate properly and safely. Amerex strongly recommends that the maintenance of portable fire extinguishers be done by a trained professional – your local authorized Amerex Distributor.

Amerex Corporation makes original factory parts available to insure proper maintenance – **USE OF SUBSTITUTE PARTS RELEASES AMEREX OF ITS WARRANTY OBLIGATIONS.** Amerex parts have machined surfaces and threads that are manufactured to exacting tolerances. O-rings, hoses, nozzles, and all metal parts meet precise specifications and are subjected to multiple in-house inspections and tests for acceptability. There are substitute parts available that may be incorrectly labeled as UL component parts, some are advertised as Amerex type. None of these meet UL requirements and all of them voids the Amerex extinguisher warranty and UL listing. **DO NOT SUBSTITUTE.**

RECHARGE FIRE EXTINGUISHERS IMMEDIATELY AFTER ANY USE

REFERENCES IN THIS MANUAL:
NFPA-10 Portable Fire Extinguishers

CGA C-1 Methods for Hydrostatic Testing of Compressed Gas Cylinders
CGA C-6 Standard for Visual Inspection of Compressed Gas Cylinders

AVAILABLE FROM:
National Fire Protection Association
1 Batterymarch Park, P.O. Box 9101
Quincy, MA 02269-9101

Compressed Gas Association, Inc.
4221 Walney Road, 5th Floor
Chantilly, VA 20151-2923

AMEREX CORPORATION – P.O. BOX 81 – TRUSSVILLE, ALABAMA 35173-0081
Phone: 205/655-3271 Fax: 800/654-5980
e-mail: sales@amerex-fire.com Web Page: <http://www.amerex-fire.com>

Printed in U.S.A.

OM05603C Rev. 3/11

**CARBON DIOXIDE HAND PORTABLE
FIRE EXTINGUISHERS**

Model 322 – 5 LB Model 331 – 15 LB
Model 330 – 10 LB Model 332 – 20 LB

AMEREX CORPORATION DOES NOT SERVICE, MAINTAIN OR RECHARGE FIRE EXTINGUISHERS. THIS MANUAL IS PUBLISHED AS A GUIDE TO ASSIST QUALIFIED SERVICE PERSONNEL IN THE INSPECTION, MAINTENANCE AND RECHARGE OF AMEREX FIRE EXTINGUISHERS ONLY. NO INSTRUCTION MANUAL CAN ANTICIPATE ALL POSSIBLE MALFUNCTIONS THAT MAY BE ENCOUNTERED IN THE SERVICE OF FIRE EXTINGUISHERS. DUE TO THE POSSIBILITY THAT PRIOR SERVICE PERFORMED ON THIS EQUIPMENT MAY HAVE BEEN IMPROPERLY DONE, IT IS EXTREMELY IMPORTANT THAT ALL WARNINGS, CAUTIONS AND NOTES IN THIS MANUAL BE CAREFULLY OBSERVED. FAILURE TO HEED THESE INSTRUCTIONS COULD RESULT IN SERIOUS INJURY.

AMEREX ASSUMES NO LIABILITY FOR SERVICE, MAINTENANCE OR RECHARGE OF FIRE EXTINGUISHERS BY PUBLISHING THIS MANUAL.

FIVE YEAR LIMITED WARRANTY

Amerex warrants its fire extinguishers to be free from defects in material and workmanship for a period of five (5) years from the date of purchase. During the warranty period, any such defects will be repaired or the defective extinguisher replaced if only factory replacement parts and recommended service equipment have been used to service the extinguisher. This warranty does not cover defects resulting from modification, alteration, misuse, exposure to unusually corrosive conditions nor improper installation or maintenance. All implied warranties, including, but not limited to, warranties of fitness for purpose and merchantability, are limited to the timer periods as stated above. In no event shall Amerex Corp. be liable for incidental or consequential damages. Some states do not allow limitations on how long an implied warranty lasts or the exclusion or limitation of incidental or consequential damages, so that the above limitations or exclusions may not apply to you. Amerex Corp. neither assumes nor authorizes any representative or other person to assume for it any obligation or liability other than expressly set forth herein. This warranty gives you specific legal rights, and you may also have other rights which may vary from state to state. To obtain performance of the obligation of this warranty, write to Amerex Corporation, P. O. Box 81, Trussville, AL 35173-0081 for instructions.

INSPECTING THE EXTINGUISHER

This extinguisher should be inspected at regular intervals (monthly or more often if circumstances dictate) to insure that it is ready for use. Inspection is a "quick check" that a fire extinguisher is available and is in operating condition. It is intended to give reasonable assurance that the fire extinguisher is fully charged. This is done by verifying that it is in its designated place, that it has not been actuated or tampered with, and that there is no obvious physical damage or condition to prevent its operation.

OPERATION

NOTE: Persons expected to use this extinguisher should be trained in initiating its operation and in the proper fire fighting technique. Familiarize all personnel with this information before an emergency occurs.

WARNING: Carbon Dioxide extinguishes fires by diluting the surrounding atmosphere with inert gas keeping the oxygen level below the percentage required for combustion. When it is used in an unventilated space, such as a small room, closet or other confined area, prolonged occupancy of that space can result in loss of consciousness due to oxygen deficiency. Avoid skin contact – CO₂ is extremely cold and could cause burns or frostbite.

1. Remove extinguisher from wall hanger or vehicle bracket and move it to within approximately 6 feet (5 lb.) or 10 feet (10, 15 or 20 lb.) of the fire site.
2. Hold the extinguisher upright, twist and pull ring (safety) pin.
3. Stand back 6 feet (5 lb.) or 10 feet (10, 15, or 20 lb.) from the fire and aim the horn at base of flames nearest you. Hold horn at base hand grip only – grasping the horn or swivel discharge tube could cause cold burn.
4. Keeping the extinguisher upright, sweep side to side across the base of the fire and past both edges. Progressively follow up until the fire is extinguished. Work the fire away from you while being alert for flashbacks. Move closer as the fire is extinguished but not so close as to scatter or splash the burning materials.
5. When the fire is out, release the valve lever to stop discharge. Stand by and watch for possible re-ignition.
6. Evacuate and ventilate the area immediately after extinguishing the fire. The fumes and smoke from any fire may be hazardous and can be deadly.

DISCHARGE TIME (APPROXIMATELY)

5 lb – 9 seconds
10 lb – 10 seconds
15 lb – 12 ½ seconds
20 lb – 19 seconds

DISCHARGE RANGE (APPROXIMATELY)

5, 10, 15, 20 lb – 3 to 8 feet

RECHARGE FIRE EXTINGUISHERS IMMEDIATELY AFTER ANY USE

INSPECTING THE EXTINGUISHER

This extinguisher should be inspected at regular intervals (monthly or more often if circumstances dictate) to insure that it is ready for use. Inspection is a "quick check" that a fire extinguisher is available and is in operating condition. It is intended to give reasonable assurance that the fire extinguisher is fully charged. This is done by verifying that it is in its designated place, that it has not been actuated or tampered with, and that there is no obvious physical damage or condition to prevent its operation.

PERIODIC INSPECTION PROCEDURES (Monthly or more often if circumstances dictate)

[NFPA-10] Periodic inspection of fire extinguishers shall include a check of at least the following items:

1. Location in designated place.
2. No obstruction to access or visibility.
3. Operating instructions on nameplate and facing outward.
4. Safety seals and tamper indicators not broken or missing.
5. Examination for obvious physical damage, corrosion, leakage, or clogged nozzle.
6. Determine fullness by weighing or hefting.

MAINTENANCE

[NFPA-10] At least once a year or more frequently if circumstances require, maintenance should be performed. Maintenance is a "thorough check" of the extinguisher. It is intended to give maximum assurance that a fire extinguisher will operate effectively and safely. It includes a thorough examination for physical damage or condition to prevent its operation and any necessary repair or replacement. It will normally reveal if hydrostatic testing or internal maintenance is required.

MAINTENANCE – SERVICE PROCEDURE

1. Clean extinguisher to remove dirt, grease or foreign material. Check to make sure that the instruction nameplate is securely attached and legible. Inspect the cylinders for corrosion, abrasion, dents or weld damage. If any damage is found, hydrostatically test in accordance with instructions in CGA C-1 and C-6 and NFPA 10.
2. Inspect the extinguisher for damaged, missing or substitute parts. Only factory replacement parts are approved for use on Amerex fire extinguishers.
3. Weigh the extinguisher and compare with weight printed in the "Maintenance" section on the nameplate (label). Recharge extinguisher if weight is not within indicated allowable tolerances.
4. Check the date of manufacture stamped on the cylinder dome. The agent cylinder must be hydrostatically tested every 5 years to the test pressure indicated on the nameplate in accordance with DOT requirements.

5. Check ring pin for freedom of movement. Replace if bent or if removal appears difficult.
6. Inspect discharge lever for any dirt or corrosion which might impair freedom of movement. Inspect carrying handle for proper installation. If lever, handle or rivets are damaged replace with proper Amerex part(s).
7. Remove the horn and discharge tube (5 lb) or hose & horn assembly (10, 25 & 20 lb), inspect for damage, replace as necessary. Replace the horn if brittle, cracked or deformed. Blow air through nozzle and nozzle assemblies to insure passage is clear of foreign material.
8. Carbon dioxide hose assemblies have a continuous metal braid that connects to both couplings to minimize static shock. A hose continuity test should be performed using a basic conductivity tester consisting of a flashlight having an open circuit and a set of two wires with a conductor (clamps or probe) at each end. (NFPA 10)
9. Inspect the valve assembly for corrosion or damage to hose thread connection. Visually inspect the safety relief assembly for obstruction or damage – replace with complete Amerex factory assembled safety relief P/N 04000 (tighten assembly to 250 in-lbs of torque) if necessary. **DO NOT SUBSTITUTE. Valve removal and/or valve part replacement should be made only after completely discharging the contents of the cylinder.**
10. Inspect the 10, 15 & 20 lb elbow and diffusion tip for blockage or damage. The Amerex 5 lb CO2 diffuser is built into the discharge tube. Check elbow and discharge tube for blockage or damage. Replace damaged parts with genuine factory replacement parts only.
11. Reinstall horn and discharge tube (5 lb) or hose and horn assembly (10, 15 & 20 lb) to discharge valve. Check horn clip (10, 15 & 20 lb) for damage or proper positioning. Replace, tighten or realign as necessary.
12. Install new tamper seal and record service data on the extinguisher inspection tag.
13. Replace the extinguisher on the wall hanger or in the vehicle bracket making sure that it fits the bracket properly and the bracket is securely attached – replace the bracket if necessary.

RECHARGE

WARNING: Before attempting to disassemble, be sure the extinguisher is completely empty/depressurized.

Use only an approved source of carbon dioxide (see minimum specifications in NFPA 10 "Inspection, Maintenance & Recharging". Do not use dry ice convertors.

Use an approved pump, hose and recharge adapter to insure safe and efficient charge operations.

RECHARGING PROCEDURE

1. Perform steps 1 through 10 of the "Maintenance-Service Procedure" section.
2. Discharge all remaining pressure and contents, making sure that there is no remaining pressure. Retighten valve assembly to 100 ft-lbs using a 16 inch wrench.
3. Check the extinguisher nameplate (label) for the proper amount of CO₂ to be pumped into the extinguisher.
4. Install the proper Amerex recharge adapter. Adapter must fit over diffuser tip on 5 lb Discharge Tube and elbow on 10, 15 & 20 lb without blocking diffuser holes. Do not remove 5 lb discharge tube or 10, 15, 20 lb elbow.
5. Place extinguisher on an accurate scale and attach carbon dioxide supply line to the recharge adapter.
6. Attach a device such as a "Pony Spring Clamp" to hold the extinguisher valve lever in the squeezed position or open position. Pump the proper amount of CO₂ into the extinguisher. When the proper weight is reached, release the clamp, shut off the CO₂ pump and vent the supply line.
7. Remove the CO₂ supply line and recharge adapter from the extinguisher valve.
8. Check the collar and valve for leaks using a leak detection fluid or a solution of soapy water. Remove leak detection fluid from the valve assembly and wipe exterior of the extinguisher to dry.
9. Install ring pin with ring facing the front of the extinguisher.
10. Install tamper seal. Record recharge date and attach new recharge tag.
11. Install the horn or hose and horn assembly to the extinguisher valve.
12. Weigh assembled extinguisher and confirm that the total weight is within the allowable tolerances indicated in the Maintenance section of the nameplate (label).

TROUBLESHOOTING GUIDE

WARNING: Determine the source of a leak before the extinguisher is depressurized. The extinguisher must be completely depressurized before any attempt is made to devalue it and correct a leakage problem. To depressurize – hold the extinguisher in a vertical position and slowly squeeze the discharge handle.

Amerex CO2 valve bodies and aluminum cylinders are 1-1/8"-12 UNF straight threads. When reinstalling the valve assembly, the cylinder must be placed in a suitable securing vice and valve installed to 100 ft-lbs of torque using a 16" wrench. Use a proper straight thread adapter when hydrostatically testing. Thoroughly clean all valve parts after depressurization and valve removal.

	PROBLEM	CORRECTIVE ACTION
1.	Leak at collar o-ring	Remove valve assembly, clean collar thoroughly and install new collar o-ring. Lubricate with Visilox V-711 and reinstall valve to a maximum of 100 ft-lbs torque.
2.	Leak through valve	Check valve stem seating area for scratches or foreign matter. Clean seating area with a tooth brush and soft cloth. Install new valve stem assembly.
3.	Leak at safety relief nut	Remove safety nut, disc and gasket assembly. Replace with new Amerex P/N 04000 safety nut, disc and gasket assembly. Tighten assembly to 250 in-lbs of torque.
4.	Leak during discharge under discharge lever	Remove valve assembly, downtube, spring and valve stem assembly. Install new valve stem assembly. Check valve seat for scratches or foreign matter.
5.	Leak during discharge at hose connection elbow	Tighten hose connection at elbow (10, 15, 20 lb). replace o-ring and/or elbow on 5 lb.
6.	Leak in the cylinder	Contact Amerex if under warranty – otherwise mark "Rejected" and remove from service or return to the owner.

**PARTS LIST
for
5 lb. Carbon Dioxide
Extinguisher Model**

**322
322MN**

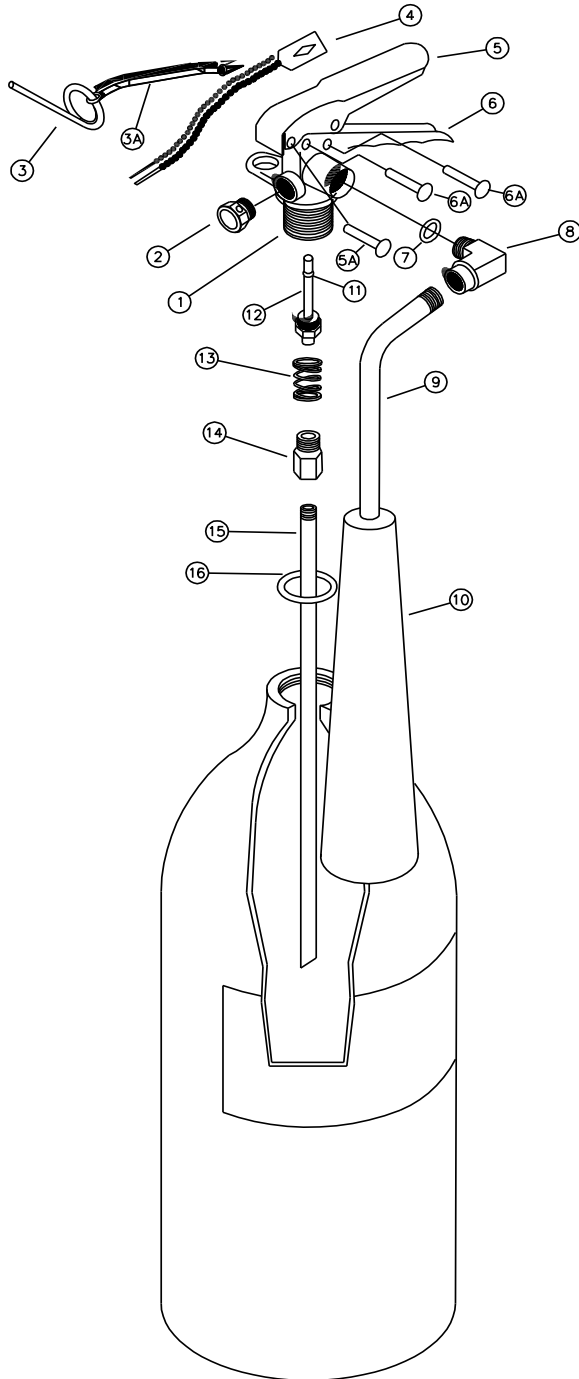

Item	Part No.	Description	Std Pkg
1	03090	Valve Assembly (does not include elbow or downtube)	1
2	04000	Safety Disc, Gasket & Nut	6
3	00160	Ring Pin, Stainless Steel	24
3A	00532	Chain (Nylon) for Ring Pin	24
4	01387	Lockwire Seal (Yellow)	500
5	07762	Lever & Rivet	1
5A	01563	Rivet only for Lever	24
6	09020	Handle & Rivets	1
6A	01564	Rivet only for Handle (2 reqd)	24
7	05689	O-ring for Elbow	6
8	02735	Elbow with O-ring	1
9	01769	Discharge Tube	1
10	01772	Horn	1
11	05235	Valve Stem O-ring	24
12	01539	Valve Stem Assembly	6
13	00501	Spring	6
14	00503	Retainer	1
15	00533	Downtube	1
16	01124	Collar O-ring 1-1/8"	24
ALL BRACKETS – SEE BRACKET PAGE			
ALL FILL & HYDROTEST ADAPTERS – SEE ADAPTER PAGE			
ALL VALVE ASSEMBLIES INCLUDE VALVE BODY, VALVE STEM ASSEMBLY, SPRING, RETAINER, LEVER & HANDLE			

**PARTS LIST
for
10-15-20 lb. Carbon Dioxide
Extinguisher Models**

**330
331
332**

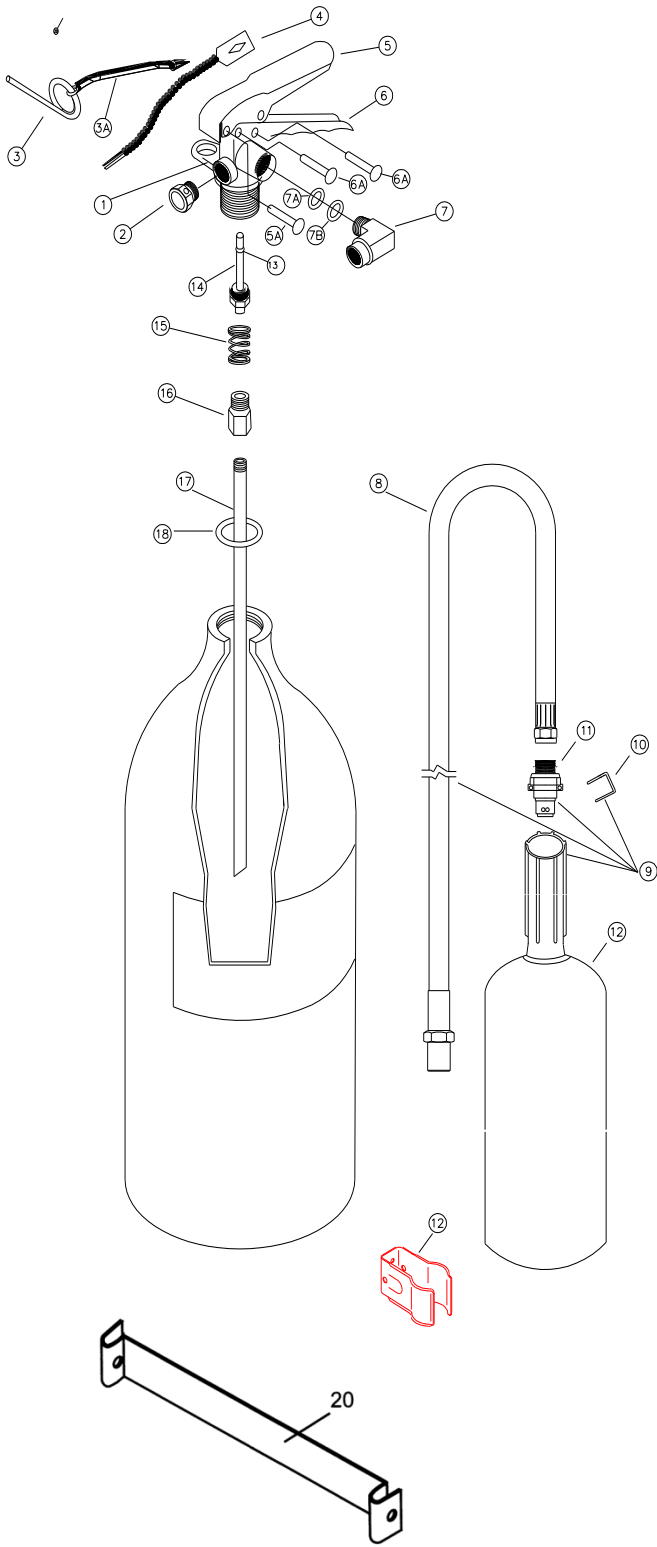

Item	Part No.	Description	Std Pkg
1	03090	Valve Assembly (does not include elbow or downtube)	1
2	04000	Safety Disc, Gasket & Nut	6
3	00160	Ring Pin, Stainless Steel	24
3A	00532	Chain (Nylon) for Ring Pin	24
4	01387	Lockwire Seal (Yellow)	500
5	07762	Lever & Rivet	1
5A	01563	Rivet only for Lever	24
6	09020	Handle & Rivets	1
6A	01564	Rivet only for Handle (2 req'd)	24
7	02309	Elbow with O-ring & Spacer	1
7A	05689	O-ring for Elbow	6
7B	02216	Nylon Spacer for Elbow	6
8	01776	Hose Assembly-330,331,332	1
9	01782	Hose & Horn Assembly-330	1
	01705	Hose & Horn Assembly-331,332	
10	00594	U-Pin	6
11	01777	Nozzle	1
12	00572	Horn - 330	1
	00593	Horn - 331, 332	
13	05235	Valve Stem O-ring	24
14	01539	Valve Stem Assembly	6
15	00501	Spring	6
16	00503	Retainer	1
17	00564	Downtube - 330	1
	00589	Downtube - 331, 332	
18	01124	Collar O-ring - 1 1/8"	24
19	02073	Horn Clip (Red)	1
20	05442	Strap (Red) for Horn Clip-330,331	1
	05441	Strap (Red) for Horn Clip - 332	
*	04489	Screw & Nut for Horn Clip Strap Assembly (NOT SHOWN)	12

ALL BRACKETS - SEE BRACKET PAGE
ALL FILL & HYDROTEST ADAPTERS - SEE ADAPTER PAGE

ALL VALVE ASSEMBLIES INCLUDE VALVE BODY, VALVE STEM ASSEMBLY, SPRING, RETAINER, LEVER & HANDLE

