



**OWNERS SERVICE MANUAL
NO. 05606
INSTALLATION, OPERATING & SERVICING INSTRUCTIONS**

All fire extinguishers should be installed, inspected and maintained in accordance with the National Fire Protection Association standard titled "Portable Fire Extinguishers", NFPA-10 and the requirements of local authorities having jurisdiction.

When maintenance is indicated, it should be performed by trained persons having proper equipment. Fire extinguishers are pressure vessels and must be treated with respect and handled with care. They are mechanical devices and require periodic maintenance to be sure that they are ready to operate properly and safely. Amerex strongly recommends that the maintenance of portable fire extinguishers be done by a trained professional – your local authorized Amerex Distributor.

Amerex Corporation makes original factory parts available to insure proper maintenance – **USE OF SUBSTITUTE PARTS RELEASES AMEREX OF ITS WARRANTY OBLIGATIONS.** Amerex parts have machined surfaces and threads that are manufactured to exacting tolerances. O-rings, hoses, nozzles, and all metal parts meet precise specifications and are subjected to multiple in-house inspections and tests for acceptability. There are substitute parts available that may be incorrectly labeled as UL component parts, some are advertised as Amerex type. None of these meet UL requirements and all of them voids the Amerex extinguisher warranty and UL listing. **DO NOT SUBSTITUTE.**

RECHARGE FIRE EXTINGUISHERS IMMEDIATELY AFTER ANY USE

REFERENCES IN THIS MANUAL:
NFPA-10 Portable Fire Extinguishers

CGA C-1 Methods for Hydrostatic Testing of Compressed Gas Cylinders
CGA C-6 Standard for Visual Inspection of Compressed Gas Cylinders

AVAILABLE FROM:
National Fire Protection Association
1 Batterymarch Park, P.O. Box 9101
Quincy, MA 02269-9101

Compressed Gas Association, Inc.
4221 Walney Road, 5th Floor
Chantilly, VA 20151-2923

AMEREX CORPORATION – P.O. BOX 81 – TRUSSVILLE, ALABAMA 35173-0081
Phone: 205/655-3271 Fax: 800/654-5980
e-mail: sales@amerex-fire.com Web Page: <http://www.amerex-fire.com>

Printed in U.S.A.

OM05606F Rev.10/09

**WHEELED STORED PRESSURE
HALON 1211 FIRE EXTINGUISHERS**
MODEL 695 (50 POUND)
MODEL 600 (150 POUND)

THIS MANUAL IS ATTACHED TO EVERY NEW EXTINGUISHER SHIPPED FROM THE FACTORY. IT CONTAINS VALUABLE INFORMATION WHICH SHOULD BE STUDIED BY EVERYONE WHO WILL USE OR SERVICE THE EXTINGUISHER. THE MANUAL SHOULD BE STORED IN A CONVENIENT LOCATION FOR EASY REFERENCE.

INTRODUCTION

Amerex Wheeled Halon 1211 fire extinguishers provide "clean agent" fire fighting capability far exceeding that achievable with hand portable types. Models 695 (50 lb.) and 600 (150 lb.) are stored pressure wheeled Halon 1211 liquefied gas extinguishers. Highly effective on Class A (ordinary combustibles), Class B (flammable liquids) and non-conductive in Class C (energized electric) hazards. Model 600 may be towed at speeds up to 15 mph over paved surfaces and can be easily managed by one person.

To provide optimum extinguisher reliability, recharging should be performed by persons trained in fire extinguisher maintenance and servicing. This manual should be used as a guide for installing and servicing these Amerex extinguishers. The best place to have your extinguishers serviced and recharged is your "Authorized Amerex Distributor" who has the professional experience and equipment to do it properly.

AMEREX CORPORATION DOES NOT SERVICE, MAINTAIN OR RECHARGE FIRE EXTINGUISHERS. THIS MANUAL IS PUBLISHED AS A GUIDE TO ASSIST QUALIFIED SERVICE PERSONNEL IN THE INSPECTION, MAINTENANCE AND RECHARGE OF AMEREX FIRE EXTINGUISHERS ONLY. NO INSTRUCTION MANUAL CAN ANTICIPATE ALL POSSIBLE MALFUNCTIONS THAT MAY BE ENCOUNTERED IN THE SERVICE OF FIRE EXTINGUISHERS. DUE TO THE POSSIBILITY THAT PRIOR SERVICE PERFORMED ON THIS EQUIPMENT MAY HAVE BEEN IMPROPERLY DONE, IT IS EXTREMELY IMPORTANT THAT ALL WARNINGS, CAUTIONS AND NOTES IN THIS MANUAL BE CAREFULLY OBSERVED. FAILURE TO HEED THESE INSTRUCTIONS COULD RESULT IN SERIOUS INJURY.

AMEREX ASSUMES NO LIABILITY FOR SERVICE, MAINTENANCE OR RECHARGE OF FIRE EXTINGUISHERS BY PUBLISHING THIS MANUAL.

PREPARING YOUR NEW EXTINGUISHER FOR USE

1. Remove all wrappings, straps and pallet retaining bolts.
2. Examine the extinguisher for shipping damage.
3. Check to insure that the hose connection at the discharge valve and the nozzle connection to the hose are tight.
4. Check to insure that the shut-off nozzle is in the closed position. The ring (safety) pin should be installed and the lockwire (tamper) seal intact.
5. Visually inspect the pressure gauge. The pressure gauge should be in the green zone (200 \pm 10 psi range). The method used to determine proper agent fill is by weighing the extinguisher. The gross weight is marked on each extinguisher nameplate.

NOTE: Halon 1211 is a liquefied gas that generates its own vapor pressure. Temperature can affect the pressure gauge reading. Normal "properly charged" markings are correct for 70°F (21°C.) Generally, as temperatures go up, pressure readings go up.

Conversely, lower temperatures result in lower readings. The relative pressure gauge vs. temperature reading for Amerex 50 and 150 lb. Halon 1211 wheeled extinguishers is as follows:

Temperature °F	-40	32	70	120
Temperature °C	-40	0	21	49
Pressure Gauge (psig)	127	168	200	263

When in doubt, condition the extinguisher to 70°F (21°C) for several hours to obtain accurate indications.

- Record the date the unit is being placed into service on the inspection tag and attach it to the extinguisher.

INSTALLATION

Do not place this extinguisher close to a potential fire hazard. Amerex recommends location no less than a 50 foot distance from the hazard while leaving an unobstructed access. Avoid placing it in an extremely hot or cold place. The operational temperature range for this extinguisher is -65° to +120°F (-54° to +49°C). The extinguisher should be adequately protected if temperatures outside of this range are anticipated. Keep the extinguisher clean and free from dirt, ice, chemicals and any contaminants which may interfere with its proper operation. Do not functionally test this fire extinguisher. (Testing or any use may cause the extinguisher to gradually lose pressure and become ineffective.)

OPERATION

WARNING: HIGH CONCENTRATIONS OF HALON 1211 CAN CAUSE RESPIRATORY PROBLEMS. CONCENTRATIONS GREATER THAN 2% BY VOLUME SHOULD BE AVOIDED.

CAUTION: Persons expected to use this extinguisher should be trained in initiating its operation and in the proper fire fighting technique. "Dry Run" and visual aid training will prepare personnel with the feel for this extinguisher so that the most effective application can be utilized in an emergency. The basic operating instructions are contained in the pictogram portion of every extinguisher nameplate (label). The following elaborates on these instructions:

- Move the extinguisher to within approximately 30 feet (50 lb.), 40 feet (150 lb.) of the fire site. Keep the extinguisher upright.

NOTE: The model 600 extinguisher may be operated in either the vertical or reclined position; however, it will discharge more agent in the vertical position. The model 695 MUST be operated in the UPRIGHT position.

- Twist and pull ring pin. Open cylinder discharge valve by rotating (pulling) the valve lever toward the hose 90°. The hose is now pressurized with chemical.
- Pull nozzle, with lever in the closed position, from the mount and extend the hose from the storage rack.

4. Stand back 15 to 20 feet from the fire and aim the nozzle at base of flames nearest you. Open nozzle by pulling handle toward you (be prepared for a discharge recoil by holding the nozzle firmly).
5. Sweep side to side across the base of the fire and past both edges. Progressively follow up until the fire is extinguished. Work the fire away from you while being alert for flashbacks. Move closer as the fire is extinguished but not so close as to scatter or splash the burning materials.
6. When the fire is out, push the nozzle lever forward to the closed position.
7. Evacuate and ventilate the area immediately after extinguishing the fire. The fumes and smoke from any fire may be hazardous and can be deadly.

WARNING: SYMPTOMS OF OVER-EXPOSURE TO PURE HALON ARE DIZZINESS, IMPAIRED COORDINATION AND REDUCED MENTAL ACUITY. PERSONS SUFFERING FROM OVER-EXPOSURE SHOULD BE IMMEDIATELY REMOVED TO FRESH AIR. IF UNCONSCIOUS GIVE RESPIRATION AND OBTAIN MEDICAL AID. USE OF ADRENALIN OR SIMILAR DRUGS SHOULD BE AVOIDED.

	MODEL 695	MODEL 600
Discharge Time (approx.)	35 seconds	44 seconds
Range (Agent Throw)	25 to 35 feet	35 to 40 feet
Hose Length	25 feet	50 feet

SHUTDOWN

CAUTION: BEFORE PERFORMING THE SHUTDOWN PROCEDURE AND PREPARING TO MOVE THE EXTINGUISHER TO THE RECHARGE LOCATION, DETERMINATION MUST BE MADE THAT THE FIRE IS COMPLETELY EXTINGUISHED AND THERE IS NO DANGER OF A FLASHBACK.

1. Rotate cylinder discharge valve lever 90° to the closed position. Install ring (locking) pin to prevent accidental actuation while transporting to recharge location.
2. Remove residual agent from hose.

CAUTION: Do not leave halon in the hose as over-pressurization and deterioration of the hose may occur.

3. Return the extinguisher to the upright position.
4. Coil the hose onto the storage rack and position the nozzle into the mount in preparation for transport to the recharge location.

RECHARGE EXTINGUISHERS IMMEDIATELY AFTER ANY USE

INSPECTING THE EXTINGUISHER

This extinguisher should be inspected at regular intervals (monthly or more often if circumstances dictate) to insure that it is ready for use. Inspection is a "quick check" that a fire extinguisher is available and is in operating condition. It is intended to give reasonable assurance that the fire extinguisher is fully charged. This is done by verifying that it is in its designated place, that it has not been actuated or tampered with, and that there is no obvious physical damage or condition to prevent its operation.

PERIODIC INSPECTION PROCEDURES (Monthly or more often if circumstances dictate)

[NFPA-10] Periodic inspection of fire extinguishers shall include a check of at least the following items:

1. Location in designated place.
2. No obstruction to access or visibility.
3. Pressure gauge reading or indicator in the operable range or position.
4. Operating instructions on nameplate and facing outward.
5. Safety seals and tamper indicators not broken or missing.
6. Examination for obvious physical damage, corrosion, leakage, or clogged nozzle.
7. Determine fullness by weighing.
8. Hose properly coiled and shut-off nozzle in its mount.
9. Wheels rotate freely.

MAINTENANCE

[NFPA-10] Maintenance is a "thorough check" of the extinguisher. It is intended to give maximum assurance that a fire extinguisher will operate effectively and safely. It includes a thorough examination for physical damage or condition to prevent its operation and any necessary repair or replacement. It will normally reveal if hydrostatic testing or internal maintenance is required.

MAINTENANCE PROCEDURE

1. Clean extinguisher to remove dirt, grease or foreign material. Check to make sure that the instruction nameplate is securely fastened and legible. Inspect the cylinders for corrosion, abrasion, dents or weld damage. If any damage is found and you doubt the integrity of the cylinder, hydrostatically test to factory test pressure, using the proof pressure method, in accordance with instructions in CGA pamphlet C-6 and NFPA 10. See proper method of depressurizing and reclaiming Halon 1211 in Complete Maintenance procedures.

NOTE: WHEN CLEANING, AVOID USE OF SOLVENTS AROUND THE PRESSURE GAUGE. THEY COULD SERIOUSLY DAMAGE THE PLASTIC GAUGE FACE.

2. Inspect the extinguisher for damaged, missing or substitute parts. Only factory replacement parts are approved for use on Amerex fire extinguishers.
3. Weigh the extinguisher and compare with weight printed in the "Maintenance" section on the nameplate (label). Recharge extinguisher if weight is not within indicated allowable tolerances.

4. Check the date of manufacture printed on the extinguisher label (nameplate) or on the agent cylinder dome. The agent cylinder must be hydrostatically (proof pressure) tested every 12 years to the test pressure indicated on the nameplate (will vary according to size). Model 695, 50 lb. (480 psi); Model 600, 150 lb. (500 psi). Discharge hoses must also be hydrostatically tested (proof pressure) every 12 years to 300 psi, or service pressure, whichever is higher.
5. Visually inspect the pressure gauge:
 - a. If bent, damaged or improper gauge, depressurize and replace.
 - b. If pressure is low, check for leaks.
 - c. If over pressurized (overcharged), depressurize the extinguisher and follow recharge instructions.
6. If the Model 600 is so equipped, check the agent lever indicator. The indicator arrow should be in the Green zone. Refer to the Trouble Shooting guide if there are any problems with the indicator.
7. Check ring pin for freedom of movement. Replace if bent or if removal appears difficult.
8. **WARNING: ALWAYS OPEN THE SHUTOFF NOZZLE HANDLE SLOWLY. ANY EVIDENCE OF AGENT IN THE NOZZLE INDICATES THAT THE UNIT MAY HAVE BEEN USED AND THE USE NOT REPORTED. BE PREPARED FOR A POSSIBLE DISCHARGE AND NOZZLE RECOIL.**

Check the nozzle shutoff lever for freedom of movement (open and close several times). If the operation is impeded, disassemble the nozzle, replace parts and/or properly lubricate as necessary. Make sure that the nozzle tip is clear and unobstructed.

9. After making sure that there is no residual pressure in the discharge hose, disconnect it from the operating valve. Blow air through the hose and nozzle assemblies to insure that the passage is clear of foreign material. Check the couplings, hose and hose gasket for damage or deterioration – replace as necessary.
10. Inspect the valve assembly for corrosion or damage to hose thread connection. Visually inspect the safety disc assembly on the Model 600 discharge valve. Replace valve assembly or component parts as necessary following the proper depressurization and recharge procedures. If valve removal is necessary, complete all steps in the Recharge Procedure.
11. Reconnect the hose to the agent cylinder. Properly coil the hose on the rack and install the nozzle (with the lever in a closed position) on the mount.

NOTE: WHEN ASSEMBLING THE HOSE TO THE AGENT CYLINDER OR NOZZLE TO THE HOSE, TIGHTEN THE COUPLING ¼ TURN AFTER CONTACTING THE HOSE GASKET.

12. Inspect the wheels on to insure they rotate freely. Lubricate as required.
13. Check carriage assembly for loose nuts, bolts, frame distortion or damage. Check welds for damage or corrosion. Replace damaged parts or make repairs as necessary.
14. Install new lockwire (tamper) seal and record service data on the extinguisher inspection tag.
15. If the extinguisher has been moved to perform service, make sure that it is returned to its proper location.

COMPLETE MAINTENANCE (SIX YEAR MAINTENANCE)

[NFPA-10] Every 6 years, stored pressure extinguishers that require a 12 year hydrostatic test shall be emptied and subjected to the applicable maintenance procedures. When the applicable maintenance procedures are performed during periodic recharging or hydrostatic testing, the six year requirement shall begin from that date.

WARNING:

- a. Before attempting to devalue the extinguisher for Maintenance, Hydrotest or Recharging be sure that it is completely depressurized. Halon 1211 generates a vapor pressure of 22 psi @ 70°F. **NEVER VENT TO THE ATMOSPHERE.** Recover agent and vapor according to the instructions below.
- b. Never have any part of your body over the extinguisher while removing the valve assembly.
- c. Halon 1211 should not be mixed with even the slightest amount of moisture. Prolonged exposure of a devalved cylinder to ambient air should be avoided to prevent moisture contamination and cylinder rusting.

COMPLETE MAINTENANCE (SIX YEAR MAINTENANCE) PROCEDURES

1. Complete items 1 through 9 in Maintenance Procedure above.
2. Attach the appropriate recharge adapter to the extinguisher operating valve on the extinguisher cylinder. Empty the extinguisher of all pressure and Halon 1211 using a listed Halon Recharge/Recovery system and a bulk Halon supply cylinder with sufficient empty capacity to accept the contents of the extinguisher.

NOTE: Every effort should be made to halt unnecessary escape of Halon 1211 to the atmosphere to prevent detrimental environmental effect. High Efficiency Halon 1211 Recharge/Recovery (vacuum pump type) systems (UL Standard 2006) are commercially available. The Getz HR-1 (UL Approved) unit assures a minimum of 99% recovery efficiency. It allows a means of checking for and removing moisture or contamination during the recovery process.

3. When extinguisher is empty of all agent and pressure, remove valve assembly and disassemble by removing downtube, spring and valve stem assembly. **Discard valve stem assembly and collar o-ring.**
4. Thoroughly clean all parts of the disassembled valve with a soft bristle brush or soft cloth. Blow the valve out with dry nitrogen.
5. Install a NEW Amerex valve stem assembly after lightly lubricating the valve stem o-ring with V-711 or equivalent (do not lubricate the valve stem seal). Reassemble the spring and downtube. Carefully install a NEW collar o-ring which has been lightly lubricated with V-711 or equivalent. Set the valve assembly aside.
6. Inspect the cylinder interior following CGA Visual Inspection Standard C-6. If a hydrotest has been performed or any moisture is evident, the cylinder should be immediately warm air dried.
7. Clean the o-ring seating groove in the cylinder neck. If any rust is evident, remove by using a fine emery cloth (200 grit). Clean the surface and lubricate the entire sealing area with a thin film of V-711 or equivalent. Install the valve assembly in extinguisher cylinder. Hand tighten firmly.
8. Use the Getz HR-1 system to purge the residual air from the extinguisher cylinder.

RECHARGE

[NFPA-10] is the replacement of the extinguishing agent (also includes the expellant for this type of extinguisher.

WARNING:

- a. Use a protective shield between you and the pressure gauge while charging an extinguisher. Do not stand in front of the gauge if a shield is not available.
- b. Use a regulated pressurizing source of dry nitrogen only with a minimum dew point of minus 70°F (minus 57°C). Set the regulator to no more than 25 psi above the extinguisher operating pressure.
- c. Check and calibrate regulator gauge at frequent intervals. The regulator gauge should be used to determine when the intended charging pressure has been reached. Do not use the extinguisher gauge for this purpose.
- d. Never leave an extinguisher connected to a regulator of a high pressure source for an extended period of time. A defective regulator could cause the cylinder to rupture due to excessive pressure.

RECHARGING PROCEDURE

1. Perform steps 1 through 8 of the "Complete Maintenance (Six Year Teardown)" section.
CAUTION: All extinguisher and charging system valves must be closed before starting this procedure.
2. Thoroughly clean all parts of the disassembled valve with a soft bristle brush or soft cloth. Blow the valve out with air or nitrogen. Inspect the collar o-ring, valve stem, spring and downtube assembly, and replace parts if worn or damaged. Lubricate the collar o-ring and small o-ring on the valve stem with Visilox V-711 (do not lubricate the valve stem seal).
3. Follow all recharging instructions on Getz HR-1 or other "approved" Recharge/Recovery System.
4. Fill extinguisher with amount of halon 1211 specified on nameplate and pressurize to the pressure specified with dry nitrogen.
5. Remove the recharge adapter. Some residual halon vapor may remain in the valve orifice as a result of the charging procedure. Before attempting to leak detect, vacuum or blow the vapor away from the areas to be checked. Check extinguisher for leaks at the valve orifice, around the collar seal, cylinder welds and gauge using a Portable Halogen Leak Detector (preferred method). The alternate method is to apply leak detecting fluid or a solution of soapy water to these areas. Use dry nitrogen to blow all liquid residue out of the valve and wipe the extinguisher to dry the exterior. **DO NOT LEAVE ANY LIQUID INSIDE THE VALVE BODY.**
6. Install hose assembly, with shut-off nozzle attached, to the extinguisher discharge valve. Tighten hose coupling ¼ turn after contact with hose gasket. Coil hose onto the hose rack and nozzle into mount.
7. Weigh extinguisher to confirm that the total weight is within the tolerances indicated in the Maintenance section of the extinguisher label (nameplate).
8. Record recharge date and attach new recharge tag in accordance with the requirements of the "Authority Having Jurisdiction".

TROUBLESHOOTING GUIDE

WARNING: Before attempting to correct any leakage problem, be sure that the agent cylinder and hose are completely depressurized. Check to determine the source of a leak before the extinguisher is depressurized. Leakage repairs will require depressurization and removal of the valve assembly. Use Getz HR-1 or other approved recharge/recovery system to depressurize extinguisher.

	PROBLEM	CORRECTIVE ACTION
1.	Pressure gauge reads high or low	Temperature may have affected pressure – see temperature/pressure relationship chart.
2.	Leak through valve	Remove valve assembly, downtube, spring and valve stem assembly. Install new valve stem assembly. Check valve seat for scratches or foreign matter.
3.	Leak at collar o-ring	Remove valve assembly, clean collar o-ring seating surface thoroughly and lubricate lightly with V-711 or equivalent. Install a new collar o-ring after lubricating with V-711 or equivalent.
4.	Leak around gauge threads	Remove gauge*, and install a new Halon 1211 gauge (see parts list) using Teflon tape on the gauge threads.
5.	Defective gauge	Remove defective gauge* and install a new Halon 1211 gauge (see parts list) using Teflon tape on the gauge threads.
6.	Visible deterioration of discharge hose	Replace hose assembly. Extinguishing agent has been stored in hose for a prolonged time. see Caution in Shut-Down procedures
	MODEL 600 ONLY	
1.	Leak at safety disc assembly	Inspect safety outlet for tightness or damage. If loose, remove entire assembly and reinstall using Teflon tape on the threads. If damaged, replace with new P/N 03787 Safety Disc Assembly using Teflon tape on the threads. Tighten only the large hex nut.
2.	Agent level gauge not functioning (if so equipped)	Remove agent level gauge and discard. Replace agent level gauge with Amerex P/N 06370
	* Pressure gauge threads are coated with a special epoxy at the factory. For easy removal, soak the valve assembly in hot water (180°F/82°C) for two to four minutes. Remove gauge with a 7/16" open end wrench.	

PARTS LIST
for
150 lb. Wheeled Stored Pressure
Halon 1211 Extinguisher
Model 600

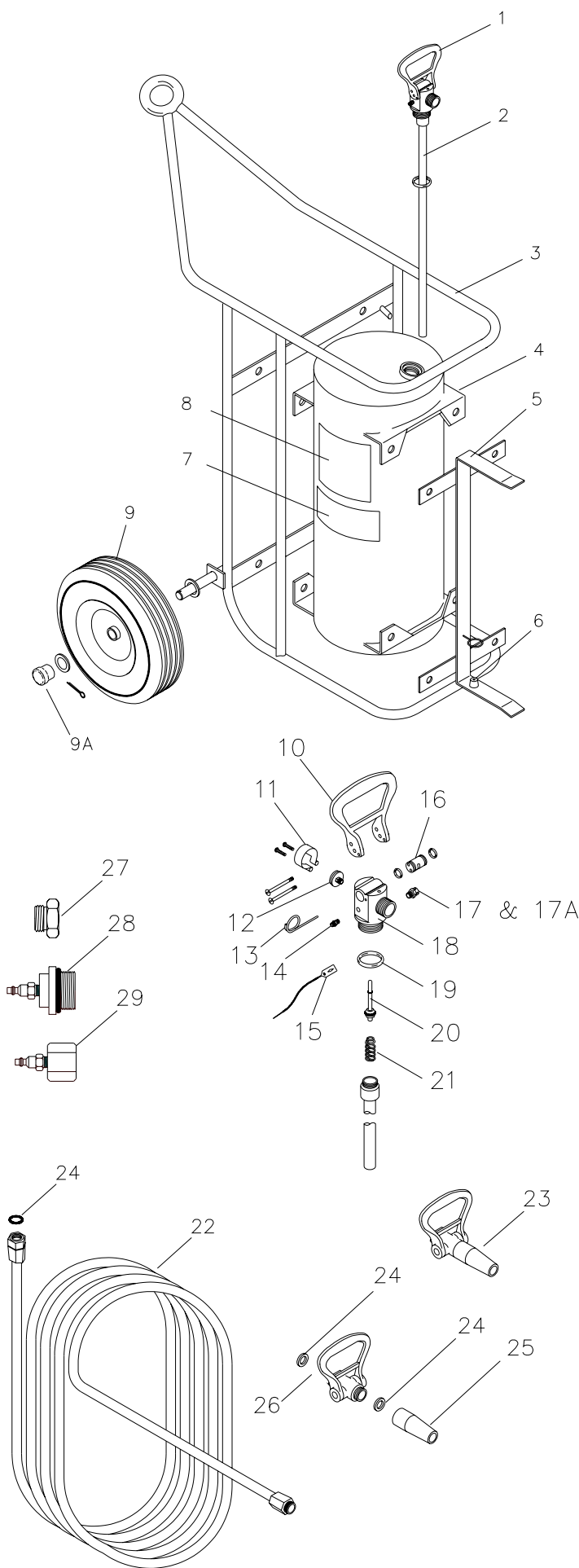

Item No.	Part No.	Description	Std. Pkg.
1	03499	Valve Assembly with Downtube	1
2	04938	Downtube/Retainer Assembly	1
3	10523	Carriage Assembly w/o Wheels	1
4	03506	Cylinder w/Mounting Brackets	1
5	06061	Hose Support Asy with Mounting Hardware	1
6	06130	Nozzle Mount with Hardware	1
7	03624	Nameplate (Mylar label) non U/L	1
8	07481	Pictogram	1
9	06062	Wheel Assembly, 16" with Hubcap, Washer and Retaining Pin Pneumatic, Green	1
9	07778	Wheel Assembly, 16" with Hubcap, Washer and Retaining Pin Semi-Pneumatic, Black	1
9A	04945	Hubcap	1
10	06059	Valve Lever w/Screws	1
11	03562	Gauge Guard Assembly	1
12	03523	200 PSI Gauge	1
13	06100	Ring Pin, SS with Wire	12
14	00155	Pressure Valve & Cap Assembly	12
15	01387	Lockwire Seal (Yellow)	500
16	06060	Cam Assembly w/o-rings	1
17	03787	Safety Disc Assembly	1
17A	13956	Vinyl Protector Cap	1
18	03678	Valve Body	1
19	05239	Collar O-Ring	12
20	05067	Valve Stem Assembly	6
21	03556	Spring	6
22	03501	Hose Assembly, 50 ft.	1
23	05295	Nozzle Asy (Ball Valve & Tip)	1
24	03877	Gasket, Hose/Nozzle	6
25	06355	Nozzle Tip (.375)	1
26	06279	Ball Valve Assembly	1
27	05723	Hydrotest Adapter (Male Plug) Use with P/N 09857 to test 50 ft. Hose Assembly	1
28	05152	Hydrotest Adapter (Cyl)	1
29	09857	Recharge Adapter	1
⊗	05606	Owners Service Manual	1
⊗	06247	Visilox Lub. (5 oz. tube)	1
⊗	06370	Plug, 3/4 NPT SS Socket	1
⊗		Part Not Pictured	

PARTS LIST
For
50 lb. Wheeled Stored Pressure
Halon 1211 Extinguisher
Model 695

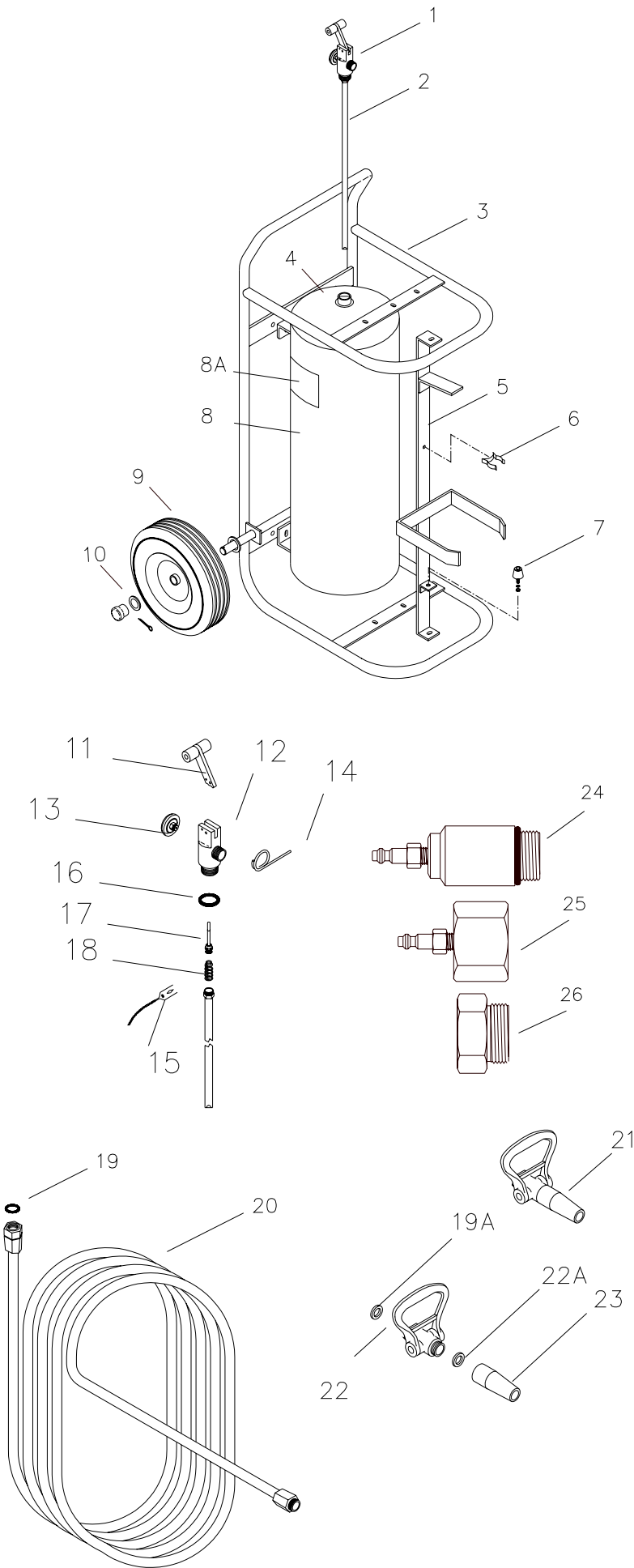

Item No.	Part No.	Description	Std. Pkg.
1	06200	Valve Assembly with Downtube	1
2	06072	Downtube Asy 50 DC	1
3	06624	Carriage Assembly w/o Wheels	1
4	00155	Pressure Valve & Cap Assembly	12
5	06379	Hose Support Asy with Hose Clip, Hardware & Nozzle Mount	1
6	06380	Hose Clip w/Mounting Hardware	1
7	06376	Nozzle Mount w/Hardware	1
8	06313	Cylinder w/Mounting Brackets	1
8A	07480	Pictogram	1
9	06381	Wheel Assembly, 12½" with Hubcap, Washer and Retaining Pin	1
10	04945	Hubcap	1
11	06373	Valve Lever w/Dowel Pin and Knobs	1
12	06153	Valve Body	1
13	03523	200 PSI Gauge	1
14	06100	Ring Pin, SS with Wire	12
15	01387	Lockwire Seal (yellow)	500
16	05240	Collar O-Ring	24
17	06022	Valve Stem Assembly	6
18	00383	Spring	6
19	07247	Gasket, Hose	6
19A	06056	Gasket, Ball Valve	6
20	06015	Hose Assembly, 25' w/Gasket	1
21	06395	Nozzle Asy (Ball Valve & Tip)	1
22	06031	Ball Valve Assembly	1
22A	03877	Gasket, Nozzle	6
23	06032	Nozzle Tip (.265)	2
24	03038	Hydrotest Adapter (Cylinder)	1
25	06160	Recharge Adapter	1
26	06157	Hydrotest Adapter (Male Plug). Use with P/N 06160 to test 25' Hose Assembly	1
⊗	06247	Visilox Lub. (5 oz. tube)	1
⊗	05606	Owners Service Manual	1
⊗	Part Not Pictured		