



Purple K Dry Chemical

*Manufactured and Tested to
ANSI/UL Standards*

*Amerex is an ISO-9001:2000
Registered Firm*

FEATURES:

- ★ Dependable Steel Cylinders
- ★ All Metal Valve Construction
- ★ Rugged - Easy and less costly to maintain and service
- ★ Bar Coded Labels for documenting extinguisher locations, inspections, maintenance and recharging.
- ★ Low Temperature Operation to -54°C

Stored Pressure



MODEL 693X
30 LB. (13.6 KG)



SPECIFICATIONS	PK Dry Chemical
Application	Hose and Horn
Model Number	693X
ULC Rating	120B:C
Capacity (lb./kg)	30 / 13.6
Shipping Wt. (lb./kg)	54 / 24.5
Height (in./cm)	26-1/8 / 66.36
Width (in./cm)	11 / 27.94
Depth (Dia. - in./cm)	8 / 20.32
Standard Bracket	Wall

The Model 693X combines a heavy duty drawn steel cylinder and chrome-plated brass valve assembly to provide a durable and attractive extinguisher suitable for high hazard Class B and C type fires which are encountered in refineries, on chemical plants, factories and flammable liquid transport vehicle requirements. Thirty pounds of fluidized and siliconized potassium bicarbonate dry chemical agent provides an extra margin of safety in the hands of an untrained fire fighter. Upright, squeeze grip operation and hose application allows easy operation. The large volume of chemical and extended discharge time make this extinguisher a valuable fire fighting tool in the hands of a trained or untrained fire fighter. **Depend on Amerex quality and over thirty years of providing the best fire extinguishers available.**



SAVA FIRE EQUIPMENT INC.

1085 Stacey Court - Mississauga, Ontario L4W 2X7
Phone: (905)238-6400 ♦ Fax: (905)238-6831
email: savafire@bellnet.ca



PARTS LIST
for
30 lb. (13.6 Kg) PURPLE K DRY CHEMICAL
EXTINGUISHER WITH HOSE AND HORN
(BRASS VALVE)

MODEL 693X

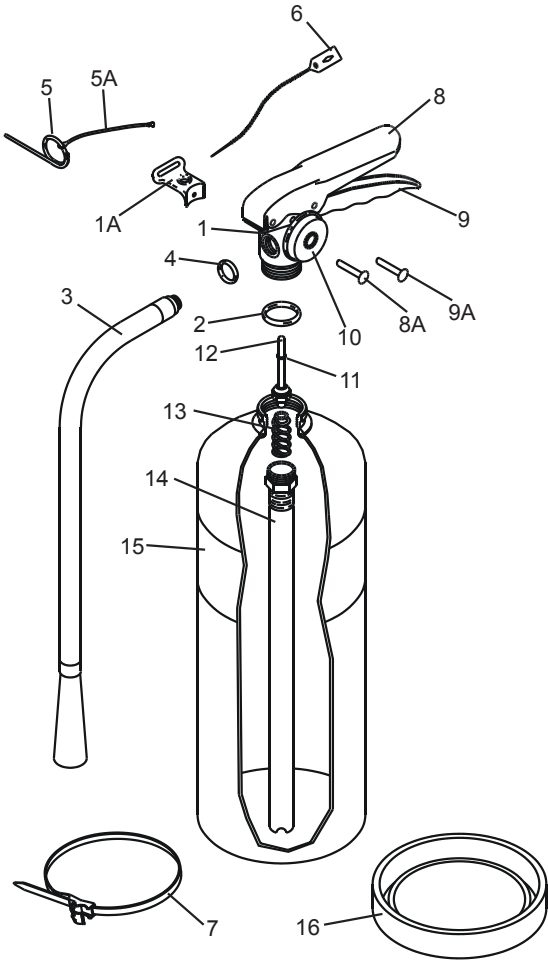

ITEM NO.	PART NO.	DESCRIPTION	STD. PKG.
1	11952	Valve Assembly	1
1A	15363	Hanger Loop and Screw	1
2	5240	Collar O-Ring	24
3	13439	Hose & Horn Ass'y - (.191)	1
4	6978	Hose Gasket (O-Ring)	24
5	0160	Ring Pin, Stainless Steel	24
5A	0532	Chain (Nylon) for Ring Pin	24
6	1387	Lock Wire Seal (Yellow)	500
7	14871	Strap & Hose Clip Ass'y (Black Plastic) 1/2"	1
8	7762	Lever & Rivet - ALL MODELS	1
8A	1563	Rivet Only for Lever	24
9	9020	Handle & Rivets - ALL MODELS	1
9A	1564	Rivets Only for Handle (2 Required)	24
10	3965	Gauge - 195 PSI	6
11	5243	Valve Stem O-Ring	24
12	6093	Valve Stem Assembly	6
13	0383	Spring	6
14	9583	Downtube/Retainer Ass'y	1
15	16895	Nameplate (Label) Non ULC	1
16	12383	Protective Ring for Bottom of Cylinder - 8"	1
*	8832	Label - WHMIS - ABC	12
*	6247	VISILOX Lubricant (5 oz. Tube)	1

* Part Not Pictured

NOTE: All Valve Assemblies include New Valve Body, Gauge, Lever and Handle

BRACKET OPTIONS

Wall Bracket
P/N: 00577

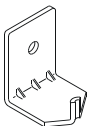

Heavy Duty Vehicle/Marine
Model: 811

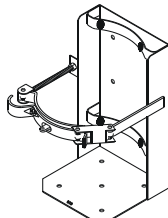

Heavy Duty Rubber Strap
Model: 864

